

Metallized Polyphenylene-Sulphide (PPS) SMD Film Capacitors with Box Encapsulation

Special Features

- Size codes 1812, 2220, 2824, 4030, 5040 and 6054 with PPS and encapsulated
- Operating temperature up to 140° C
- Self-healing
- Suitable for lead-free soldering
- Low dissipation factor
- Low dielectric absorption
- Very constant capacitance value versus temperature
- According to RoHS 2002/95/EC

Typical Applications

For general applications in high temperature circuits e.g.

- By-pass
- Blocking
- Coupling and decoupling
- Timing
- Filtering
- Oscillating circuits

Construction

Dielectric:

Polyphenylene-sulphide (PPS) film

Capacitor electrodes:

Vacuum-deposited

Internal construction:

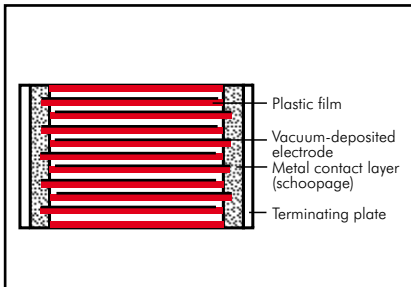

Encapsulation:

Solvent-resistant, flame-retardant plastic case, UL 94 V-0

Terminations:

Tinned plates.

Marking:

Box colour: Black.

Electrical Data

Capacitance range:

0.01 µF to 6.8 µF

Rated voltages:

63 VDC, 100 VDC, 250 VDC, 400 VDC, 630 VDC, 1000 VDC

Capacitance tolerances:

±20%, ±10% (±5% available subject to special enquiry)

Operating temperature range:

-55° C to +140° C

Climatic test category:

55/140/56 in accordance with IEC

Insulation resistance at +20° C:

| U _r | U _{test} | C ≤ 0.33 µF | 0.33 µF < C ≤ 6.8 µF |
|-------------------|-------------------|--|---|
| 63 VDC 100 VDC | 50 V 100 V | ≥ 1 × 10 ⁴ MΩ (mean value: 3 × 10 ⁴ MΩ) | ≥ 3000 sec (MΩ × µF) (mean value: 6000 sec) |
| ≥ 250 VDC | 100 V | ≥ 3 × 10 ⁴ MΩ (mean value: 6 × 10 ⁴ MΩ) | ≥ 6000 sec (MΩ × µF) (mean value: 12000 sec) |

Measuring time: 1 min.

Dissipation factors at +20° C: tan δ

| at f | C ≤ 0.1 µF | 0.1 µF < C ≤ 1.0 µF | C > 1.0 µF |
|---------|-------------------------|-------------------------|-------------------------|
| 1 kHz | ≤ 15 × 10 ⁻⁴ | ≤ 20 × 10 ⁻⁴ | ≤ 20 × 10 ⁻⁴ |
| 10 kHz | ≤ 20 × 10 ⁻⁴ | ≤ 25 × 10 ⁻⁴ | - |
| 100 kHz | ≤ 50 × 10 ⁻⁴ | - | - |

Maximum pulse rise time: for pulses equal to the rated voltage

| Capacitance µF | Pulse rise time V/µsec max. operation/test | | | | | |
|-------------------|---|---------|---------|---------|---------|----------|
| | 63 VDC | 100 VDC | 250 VDC | 400 VDC | 630 VDC | 1000 VDC |
| 0.01 ... 0.022 | 25/250 | 25/250 | 30/300 | 35/350 | 40/400 | 45/450 |
| 0.033 ... 0.068 | 15/150 | 15/150 | 20/200 | 25/250 | 28/280 | 32/320 |
| 0.1 ... 0.22 | 10/100 | 10/100 | 12/120 | 15/150 | - | - |
| 0.33 ... 0.68 | 5/50 | 5/50 | 6/60 | 8/80 | - | - |
| 1.0 ... 2.2 | 3/30 | 3/30 | - | - | - | - |
| 3.3 ... 6.8 | 2/20 | - | - | - | - | - |

Dip Solder Test/Processing

Resistance to soldering heat:

Test Tb in accordance with DIN IEC

60068-2-58/DIN EN 60384-20.

Soldering bath temperature max. 260° C.

Soldering duration max. 5 sec.

Change in capacitance ΔC/C < 5%.

Soldering process:

Wave soldering and re-flow soldering
(see temperature/time graphs page 12).

Packing

Available taped and reeled in 12 mm blister pack.

Detailed taping information and graphs at the end of the catalogue.

For further details and graphs please refer to Technical Information.

Continuation

General Data

| Capacitance | 63 VDC/40 VAC* | | | 100 VDC/63 VAC* | | | 250 VDC/160 VAC* | | | | | |
|-------------|----------------|------------|---------------------|-----------------|------------|---------------------|------------------|---------------------|---------------------|---------------------|-----|---------------------|
| | Size code | H ± 0.3 | Part number | Size code | H ± 0.3 | Part number | Size code | H ± 0.3 | Part number | | | |
| 0.01 µF | 1812 | 3.0 | SMDIC02100X100_____ | 1812 | 3.0 | SMDID02100X100_____ | 2220 | 3.5 | SMDIF02100Y100_____ | | | |
| | 2220 | 3.5 | SMDIC02100Y100_____ | 2220 | 3.5 | SMDID02100Y100_____ | | | | | | |
| 0.015 " | 1812 | 3.0 | SMDIC02150X100_____ | 1812 | 3.0 | SMDID02150X100_____ | 2220 | 3.5 | SMDIF02150Y100_____ | | | |
| | 2220 | 3.5 | SMDIC02150Y100_____ | 2220 | 3.5 | SMDID02150Y100_____ | | | | | | |
| 0.022 " | 1812 | 3.0 | SMDIC02220X100_____ | 1812 | 3.0 | SMDID02220X100_____ | 2220 | 3.5 | SMDIF02220Y100_____ | | | |
| | 2220 | 3.5 | SMDIC02220Y100_____ | 2220 | 3.5 | SMDID02220Y100_____ | | 2824 | 3.0 | SMDIF02220T100_____ | | |
| 0.033 " | 1812 | 3.0 | SMDIC02330X100_____ | 1812 | 3.0 | SMDID02330X100_____ | 2824 | 3.0 | SMDIF02330T100_____ | | | |
| | 2220 | 3.5 | SMDIC02330Y100_____ | 2220 | 3.5 | SMDID02330Y100_____ | | 4030 | 5.0 | SMDIF02330K100_____ | | |
| | 2824 | 3.0 | SMDIC02330T100_____ | 2824 | 3.0 | SMDID02330T100_____ | | | | | | |
| 0.047 " | 1812 | 3.0 | SMDIC02470X100_____ | 1812 | 3.0 | SMDID02470X100_____ | 2824 | 5.0 | SMDIF02470T200_____ | | | |
| | 2220 | 3.5 | SMDIC02470Y100_____ | 2220 | 3.5 | SMDID02470Y100_____ | | 4030 | 5.0 | SMDIF02470K100_____ | | |
| | 2824 | 3.0 | SMDIC02470T100_____ | 2824 | 3.0 | SMDID02470T100_____ | | | | | | |
| 0.068 " | 1812 | 3.0 | SMDIC02680X100_____ | 2220 | 3.5 | SMDID02680Y100_____ | 2824 | 5.0 | SMDIF02680T200_____ | | | |
| | 2220 | 3.5 | SMDIC02680Y100_____ | 2824 | 3.0 | SMDID02680T100_____ | | 4030 | 5.0 | SMDIF02680K100_____ | | |
| | 2824 | 3.0 | SMDIC02680T100_____ | | | | | | | | | |
| 0.1 µF | 1812 | 3.0 | SMDIC03100X100_____ | 2220 | 3.5 | SMDID03100Y100_____ | 2824 | 5.0 | SMDIF03100T200_____ | | | |
| | 2220 | 3.5 | SMDIC03100Y100_____ | 2824 | 3.0 | SMDID03100T100_____ | | 4030 | 5.0 | SMDIF03100K100_____ | | |
| | 2824 | 3.0 | SMDIC03100T100_____ | | 5040 | 6.0 | | SMDIF03100V100_____ | | | | |
| 0.15 " | 1812 | 4.0 | SMDIC03150X200_____ | 2824 | 3.0 | SMDID03150T100_____ | 4030 | 5.0 | SMDIF03150K100_____ | | | |
| | 2220 | 3.5 | SMDIC03150Y100_____ | | | | 5040 | 6.0 | SMDIF03150V100_____ | | | |
| | 2824 | 3.0 | SMDIC03150T100_____ | | | | 6054 | 7.0 | SMDIF03150Q100_____ | | | |
| 0.22 " | 1812 | 4.0 | SMDIC03220X200_____ | 2220 | 4.5 | SMDID03220Y200_____ | 4030 | 5.0 | SMDIF03220K100_____ | | | |
| | 2220 | 4.5 | SMDIC03220Y200_____ | 2824 | 5.0 | SMDID03220T200_____ | | 5040 | 6.0 | SMDIF03220V100_____ | | |
| | 2824 | 5.0 | SMDIC03220T200_____ | | 6054 | 7.0 | | SMDIF03220Q100_____ | | | | |
| 0.33 " | 2220 | 4.5 | SMDIC03330Y200_____ | 2824 | 5.0 | SMDID03330T200_____ | 5040 | 6.0 | SMDIF03330V100_____ | | | |
| | 2824 | 5.0 | SMDIC03330T200_____ | | | | 4030 | 5.0 | SMDID03330K100_____ | 6054 | 7.0 | SMDIF03330Q100_____ |
| | 4030 | 5.0 | SMDIC03330K100_____ | | | | | | | | | |
| 0.47 " | 2220 | 4.5 | SMDIC03470Y200_____ | 2824 | 5.0 | SMDID03470T200_____ | 6054 | 7.0 | SMDIF03470Q100_____ | | | |
| | 2824 | 5.0 | SMDIC03470T200_____ | | | | | | | | | |
| | 4030 | 5.0 | SMDIC03470K100_____ | | | | | | | | | |
| 0.68 " | 2824 | 5.0 | SMDIC03680T200_____ | 4030 | 5.0 | SMDID03680K100_____ | | | | | | |
| | 4030 | 5.0 | SMDIC03680K100_____ | | | | | | | | | |
| 1.0 µF | 2824 | 5.0 | SMDIC04100T200_____ | 5040 | 6.0 | SMDID04100V100_____ | | | | | | |
| | 4030 | 5.0 | SMDIC04100K100_____ | | | | | | | | | |
| | 5040 | 6.0 | SMDIC04100V100_____ | | | | | | | | | |
| 1.5 " | 4030 | 5.0 | SMDIC04150K100_____ | 6054 | 7.0 | SMDID04150Q100_____ | | | | | | |
| | 5040 | 6.0 | SMDIC04150V100_____ | | | | | | | | | |
| 2.2 " | 5040 | 6.0 | SMDIC04220V100_____ | 6054 | 7.0 | SMDID04220Q100_____ | | | | | | |
| | 6054 | 7.0 | SMDIC04220Q100_____ | | | | | | | | | |
| 3.3 " | 5040 | 6.0 | SMDIC04330V100_____ | | | | | | | | | |
| | 6054 | 7.0 | SMDIC04330Q100_____ | | | | | | | | | |
| 4.7 " | 6054 | 7.0 | SMDIC04470Q100_____ | | | | | | | | | |
| 6.8 " | 6054 | 7.0 | SMDIC04680Q100_____ | | | | | | | | | |

Part number completion:

Tolerance: 20 % = M

10 % = K

5 % = J

Packing: bulk = S

Pin length: none = 00

Taped version see page 126.

* AC voltages: $f \leq 400 \text{ Hz}$; $1.4 \times U_{\text{rms}} + U_{\text{DC}} \leq U_{\text{r}}$

Dims. in mm.

Rights reserved to amend design data without prior notification.

Continuation

General Data

| Capacitance | 400 VDC/200 VAC* | | | 630 VDC/300 VAC* | | | 1000 VDC/400 VAC* | | |
|--------------------|----------------------|-------------------|---|------------------|------------|---------------------|-------------------|------------|---------------------|
| | Size code | H ± 0.3 | Part number | Size code | H ± 0.3 | Part number | Size code | H ± 0.3 | Part number |
| 0.01 μF | | | | 5040 | 6.0 | SMDIJ02100V100_____ | 5040 | 6.0 | SMDIO12100V100_____ |
| 0.015 „ | | | | 5040 | 6.0 | SMDIJ02150V100_____ | 5040 | 6.0 | SMDIO12150V100_____ |
| 0.022 „ | 4030 5040 | 5.0 6.0 | SMDIG02220K100_____ SMDIG02220V100_____ | 5040 | 6.0 | SMDIJ02220V100_____ | 6054 | 7.0 | SMDIO12220Q100_____ |
| 0.033 „ | 4030 5040 | 5.0 6.0 | SMDIG02330K100_____ SMDIG02330V100_____ | 5040 | 6.0 | SMDIJ02330V100_____ | 6054 | 7.0 | SMDIO12330Q100_____ |
| 0.047 „ | 4030 5040 | 5.0 6.0 | SMDIG02470K100_____ SMDIG02470V100_____ | 5040 | 6.0 | SMDIJ02470V100_____ | | | |
| 0.068 „ | 4030 5040 | 5.0 6.0 | SMDIG02680K100_____ SMDIG02680V100_____ | | | | | | |
| 0.1 μF | 4030 5040 6054 | 5.0 6.0 7.0 | SMDIG03100K100_____ SMDIG03100V100_____ SMDIG03100Q100_____ | | | | | | |
| 0.15 „ | 5040 6054 | 6.0 7.0 | SMDIG03150V100_____ SMDIG03150Q100_____ | | | | | | |
| 0.22 „ | 6054 | 7.0 | SMDIG03220Q100_____ | | | | | | |
| 0.33 „ | 6054 | 7.0 | SMDIG03330Q100_____ | | | | | | |

* AC voltages: $f \leq 400 \text{ Hz}$; $1.4 \times U_{\text{rms}} + U_{\text{DC}} \leq U_{\text{r}}$

Dims. in mm.

Solder pad recommendation

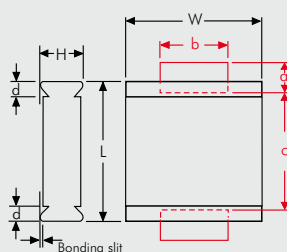

Part number completion:

Tolerance: 20 % = M
10 % = K
5 % = J

Packing: bulk = S
Pin length: none = 00

Taped version see page 126.

| Size code | L ±0.3 | W ±0.3 | d | a min. | b min. | c max. |
|-----------|-----------|-----------|-----|-----------|-----------|-----------|
| 1812 | 4.8 | 3.3 | 0.5 | 1.2 | 3.5 | 3.5 |
| 2220 | 5.7 | 5.1 | 0.5 | 1.2 | 4 | 4.5 |
| 2824 | 7.2 | 6.1 | 0.5 | 1.2 | 4 | 6.5 |
| 4030 | 10.2 | 7.6 | 0.5 | 2.5 | 6 | 9 |
| 5040 | 12.7 | 10.2 | 0.7 | 2.5 | 6 | 11.5 |
| 6054 | 15.3 | 13.7 | 0.7 | 2.5 | 6 | 14 |

Rights reserved to amend design data without prior notification.

Recommendation for Processing and Application of SMD Capacitors

Layout Form

The components can generally be positioned on the carrier material as desired. In order to prevent soldering shadows or ensure regular temperature distribution, extreme concentration of the components should be avoided. In practice, it has proven best to keep a minimum distance of the soldering surfaces between two WIMA SMDs of twice the height of the components.

Solder Pad Recommendation

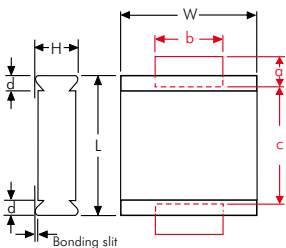

| Size code | L ± 0.3 | W ± 0.3 | d | a min. | b min. | c max. |
|-----------|------------|------------|-----|-----------|-----------|-----------|
| 1812 | 4.8 | 3.3 | 0.5 | 1.2 | 3.5 | 3.5 |
| 2220 | 5.7 | 5.1 | 0.5 | 1.2 | 4 | 4.5 |
| 2824 | 7.2 | 6.1 | 0.5 | 1.2 | 4 | 6.5 |
| 4030 | 10.2 | 7.6 | 0.5 | 2.5 | 6 | 9 |
| 5040 | 12.7 | 10.2 | 0.7 | 2.5 | 6 | 11.5 |
| 6054 | 15.3 | 13.7 | 0.7 | 2.5 | 6 | 14 |

The solder pad size recommendations given for each individual series are to be understood as minimum dimensions which can at any time be adjusted to the layout form.

Processing

The processing of SMD components

- assembling
- soldering
- washing
- electrical final inspection/ calibrating

must be regarded as a complete process. The soldering of the printed circuit board, for example, can constitute considerable stress on all the electronic components. The manufacturer's instructions on the processing of the components are mandatory.

Soldering Process

Re-flow soldering

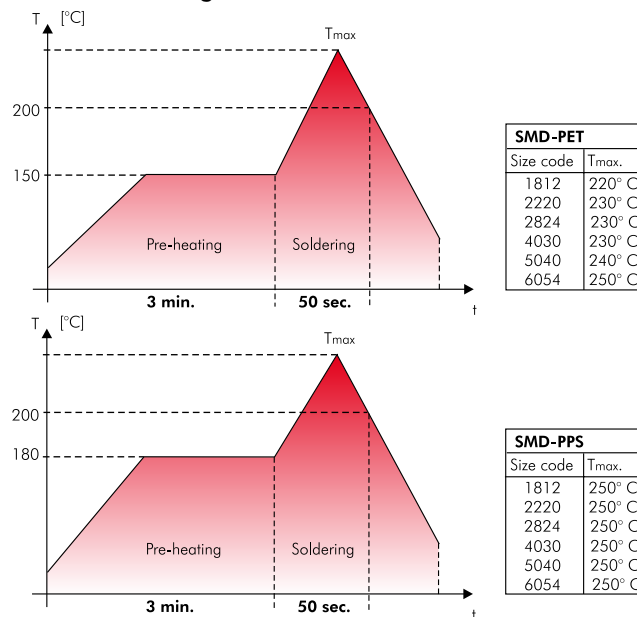

Temperature/time graph for the permissible processing temperature of the WIMA SMD film capacitor for typical convection soldering processes.

Due to the diverse procedures and the varying heat requirements of the different types of components, an exact processing temperature for re-flow soldering processes cannot be specified. The graph shows the upper limits of temperature and time which

must not be exceeded when establishing the solder profile according to your actual requirements.

A max. temperature of $T = 210^{\circ}\text{C}$ inside the component should not be exceeded when processing WIMA SMD capacitors.

SMD Handsoldering

WIMA SMD capacitors with plastic film dielectric are generally suitable for hand-soldering with a soldering iron where, however, similar to automated soldering processes, a certain duration and temperature should not be exceeded. These parameters are dependent on the physical size of the components and the relevant heat absorption involved.

The below data are to be regarded as guideline values and should serve to avoid damage to the dielectric caused by excessive heat during the soldering process. The soldering quality depends on the tool used and on the skill and experience of the person with the soldering iron in hand.

| Size code | Temperature °C / °F | Time duration |
|-----------|---------------------|---|
| 1812 | 225 / 437 | 2 sec plate 1 / 5 sec off / 2 sec plate 2 |
| 2220 | 225 / 437 | 3 sec plate 1 / 5 sec off / 3 sec plate 2 |
| 2824 | 250 / 482 | 3 sec plate 1 / 5 sec off / 3 sec plate 2 |
| 4030 | 260 / 500 | 5 sec plate 1 / 5 sec off / 5 sec plate 2 |
| 5040 | 260 / 500 | 5 sec plate 1 / 5 sec off / 5 sec plate 2 |
| 6054 | 260 / 500 | 5 sec plate 1 / 5 sec off / 5 sec plate 2 |

Recommendation for Processing and Application of SMD Capacitors (Continuation)

Solder Paste

To obtain the best soldering performance we suggest the use of following solder paste alloy:

Lead free solder paste

Sn - Bi
Sn - Zn (Bi)
Sn - Ag - Cu

Solder paste with lead

Sn - Pb - Ag (Sn60-Pb40-A, Sn63-Pb37-A)

Washing

Basically, all plastic encapsulated components, irrespective of the brand cannot be considered as being hermetically sealed. They are therefore only suitable for industrial washing processes to a limited extent. During the washing process, washing agents can penetrate the interior of the component by capillary action through microcracks which might have occurred. This is dependent on a number of parameters e.g.

- washing agents
- viscosity of the washing solvent
- temperature/time of the washing process
- mechanical washing aids such as ultrasonic water pressure rinsing and spraying pressure

The type of washing agent to be used is largely specific to the individual user or is often laid down by the manufacturer of the washing equipment. The aggressiveness of the washing agent to be used can thus only be judged in appropriate test series relating to each individual washing process. By and large, the basic rule is that the washing process should be carried out as gently as possible.

Drying

During the washing process, aqueous solutions can penetrate the component. This can lead to changes of the electrical parameters. Suitable drying measures should ensure that no residual moisture or traces of washing substances are left in the component.

Initial Operation/Calibration

Due to the stress which the components are subjected to during processing, reversible parameter changes occur in almost all electronic components. The capacitance recovery accuracy to be expected with careful processing is within a scope of $|\Delta C/C| \leq 5\%$.

For the initial operation of the device a minimum storage time of $t \geq 24$ hours

is to be taken into account. With calibrated devices or when the application is largely dependent on capacitance it is advisable to prolong the storage time to $t \geq 10$ days

In this way ageing effects of the capacitor structure can be anticipated. Parameter changes due to processing are not to be expected after this period of time

Humidity Protection Bags

Taped WIMA SMD capacitors are shipped in humidity protection bags according to JEDEC standard, level 1 (EMI/static-shielding bags conforming to MIL-B 81705, Type 1, Class 1). Under controlled conditions the components can be stored two years and more in the originally sealed bag. Opened packing units should be consumed instantly or resealed for specific storage under controlled conditions.

Reliability

Taking account of the manufacturer's guidelines and compatible processing, the WIMA SMD stand out for the same high quality and reliability as the analogous through-hole WIMA series. The technology of metallized film capacitors used e.g. in WIMA SMD-PET achieves the best values for all fields of application. The expected value is about:

$$\lambda_0 \leq 2 \text{ fit}$$

Furthermore the production of all WIMA components is subject to the regulations laid down by ISO 9001:2008 as well as

the guidelines for component specifications set out by IEC quality assessment system (IECQ-CECC) for electronic components.

Electrical Characteristics and Fields of Application

Basically the WIMA SMD series have the same electrical characteristics as the analogous through-hole WIMA capacitors. Compared to ceramic or tantalum dielectrics WIMA SMD capacitors have a number of other outstanding qualities :

- favourable pulse rise time
- low ESR
- low dielectric absorption
- available in high voltage series
- large capacitance spectrum
- stand up to high mechanical stress
- good long-term stability

As regards technical performance as well as quality and reliability, the WIMA SMD series offer the possibility to cover nearly all applications of conventionally through-hole film capacitors with SMD components. Furthermore, the WIMA SMD series can now be used for all the demanding capacitor applications for which, in the past, the use of through-hole components was mandatory:

- measuring techniques
- oscillator circuits
- differentiating and integrating circuits
- A/D or D/A transformers
- sample and hold circuits
- automotive electronics

With the WIMA SMD programme available today, the major part of all plastic film capacitors can be replaced by WIMA SMD components. The field of application ranges from standard coupling capacitors to use in switch-mode power supplies as filter or charging capacitors with high voltage and capacitance values, as well as in telecommunications e.g. the well-known telephone capacitor $1\mu\text{F}/250\text{VDC}$.



Blister Tape Packaging and Packing Units of the WIMA SMD Capacitors

Tape reel:

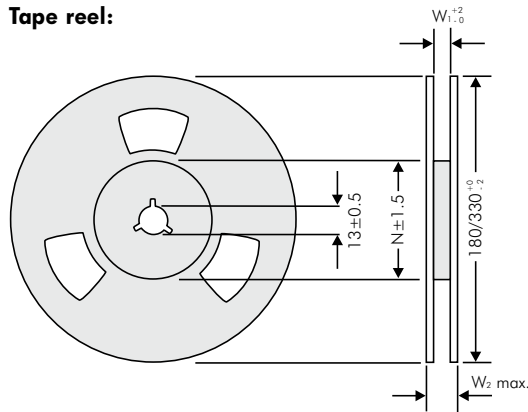

Tape advance and return:

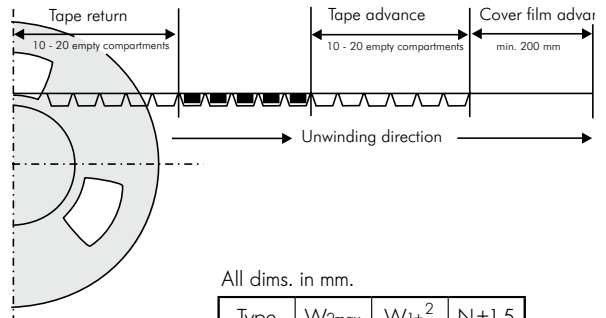

All dims. in mm.

| Type | W _{2max} | W _{1±0.2} | N±1.5 |
|------|-------------------|--------------------|-------|
| 1812 | 19 | 12.4 | 62 |
| 2220 | 19 | 12.4 | 62 |
| 2824 | 19 | 12.4 | 62 |
| 4030 | 22.4 | 16.4 | 60 |
| 5040 | 30.4 | 24.4 | 90 |
| 6054 | 30.4 | 24.4 | 90 |

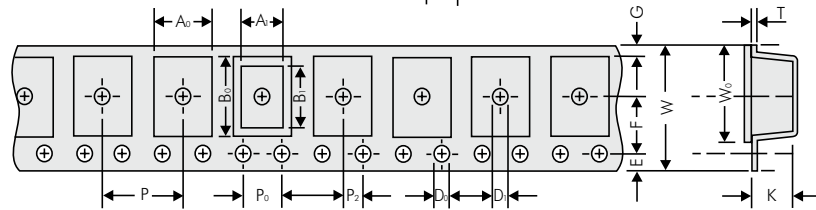

Packing units

| Size Code 1812 | | A ₀ ±0.1 | A ₁ | B ₀ ±0.1 | B ₁ | D ₀ +0.1 -0 | D ₁ +0.1 -0 | P ±0.1 | P ₀ * ±0.1 | P ₂ ±0.05 | E ±0.1 | F ±0.05 | G | W ±0.3 | W ₀ ±0.2 | K ±0.1 | T ±0.1 |
|----------------|-----------|---------------------|----------------|---------------------|----------------|------------------------|------------------------|--------|-----------------------|----------------------|--------|---------|-----|--------|---------------------|--------|--------|
| Box size | Code | | | | | | | | | | | | | | | | |
| 4.8x3.3x3 | X1 | 3.55 | 3.3 | 5.1 | 4.8 | ∅1.5 | ∅1.5 | 8 | 4 | 2 | 1.75 | 5.5 | 2.2 | 12 | 9.5 | 3.4 | 0.3 |
| 4.8x3.3x4 | X2 | 3.55 | 3.3 | 5.1 | 4.8 | ∅1.5 | ∅1.5 | 8 | 4 | 2 | 1.75 | 5.5 | 2.2 | 12 | 9.5 | 4.4 | 0.3 |

| taped Reel 180 mm ∅ | taped Reel 330 mm ∅ | bulk | |
|---------------------|---------------------|------|----------|
| | | Mini | Standard |
| 750 | 2500 | 1000 | 3000 |
| 500 | 2000 | 1000 | 3000 |

| Size Code 2220 | | A ₀ ±0.1 | A ₁ | B ₀ ±0.1 | B ₁ | D ₀ +0.1 -0 | D ₁ +0.1 -0 | P ±0.1 | P ₀ * ±0.1 | P ₂ ±0.05 | E ±0.1 | F ±0.05 | G | W ±0.3 | W ₀ ±0.2 | K ±0.1 | T ±0.1 |
|----------------|-----------|---------------------|----------------|---------------------|----------------|------------------------|------------------------|--------|-----------------------|----------------------|--------|---------|------|--------|---------------------|--------|--------|
| Box size | Code | | | | | | | | | | | | | | | | |
| 5.7x5.1x3.5 | Y1 | 6.3 | 5.7 | 5.6 | 5.1 | ∅1.5 | ∅1.5 | 8 | 4 | 2 | 1.75 | 5.5 | 1.95 | 12 | 9.5 | 3.7 | 0.3 |
| 5.7x5.1x4.5 | Y2 | 6.3 | 5.7 | 5.6 | 5.1 | ∅1.5 | ∅1.5 | 8 | 4 | 2 | 1.75 | 5.5 | 1.95 | 12 | 9.5 | 4.7 | 0.3 |

| taped Reel 180 mm ∅ | taped Reel 330 mm ∅ | bulk | |
|---------------------|---------------------|------|----------|
| | | Mini | Standard |
| 500 | 1800 | 1000 | 3000 |
| 400 | 1500 | 1000 | 3000 |

| Size Code 2824 | | A ₀ ±0.1 | A ₁ | B ₀ ±0.1 | B ₁ | D ₀ +0.1 -0 | D ₁ +0.1 -0 | P ±0.1 | P ₀ * ±0.1 | P ₂ ±0.05 | E ±0.1 | F ±0.05 | G | W ±0.3 | W ₀ ±0.2 | K ±0.1 | T ±0.1 |
|----------------|-----------|---------------------|----------------|---------------------|----------------|------------------------|------------------------|--------|-----------------------|----------------------|--------|---------|-----|--------|---------------------|--------|--------|
| Box size | Code | | | | | | | | | | | | | | | | |
| 7.2x6.1x3 | T1 | 6.6 | 6.1 | 7.7 | 7.2 | ∅1.5 | ∅1.5 | 12 | 4 | 2 | 1.75 | 5.5 | 0.9 | 12 | 9.5 | 3.4 | 0.3 |
| 7.2x6.1x5 | T2 | 6.6 | 6.1 | 7.7 | 7.2 | ∅1.5 | ∅1.5 | 12 | 4 | 2 | 1.75 | 5.5 | 0.9 | 12 | 9.5 | 5.4 | 0.4 |

| taped Reel 330 mm ∅ | bulk | |
|---------------------|------|----------|
| | Mini | Standard |
| 1500 | 500 | 2000 |
| 750 | 500 | 2000 |

| Code | A ₀ ±0.1 | A ₁ | B ₀ ±0.1 | B ₁ | D ₀ +0.1 -0 | D ₁ +0.1 -0 | P ±0.1 | P ₀ * ±0.1 | P ₂ ±0.05 | E ±0.1 | F ±0.05 | G | W ±0.3 | W ₀ ±0.2 | K ±0.1 | T ±0.1 | |
|-----------------------|---------------------|----------------|---------------------|----------------|------------------------|------------------------|--------|-----------------------|----------------------|--------|---------|------|--------|---------------------|--------|--------|-----|
| Size Code 4030 | K1 | 10.7 | 10.2 | 8.1 | 9.1 | ∅1.5 | ∅1.5 | 16 | 4 | 2 | 1.75 | 7.5 | 1.9 | 16 | 13.3 | 5.5 | 0.3 |
| Size Code 5040 | V1 | 13.5 | 12.7 | 11 | 11.5 | ∅1.5 | ∅1.5 | 16 | 4 | 2 | 1.75 | 11.5 | 4.7 | 24 | 21.3 | 6.5 | 0.3 |
| Size Code 6054 | Q1 | 17.0 | 16.5 | 15.6 | 15.0 | ∅1.5 | ∅1.5 | 20 | 4 | 2 | 1.75 | 11.5 | 2.95 | 24 | 21.3 | 7.5 | 0.3 |

| taped Reel 330 mm ∅ | bulk | |
|---------------------|------|----------|
| | Mini | Standard |
| 775 | 500 | 2000 |
| 600 | 200 | 1000 |
| 450 | 100 | 500 |

* cumulative after 10 steps ± 0.2 mm max.
Samples and pre-production needs on request or 1 Reel minimum.

Part number codes for SMD packing

| W (Blister) | ∅ in mm | Code |
|-------------|---------|----------|
| 12 | 180 | P |
| 12 | 330 | Q |
| 16 | 330 | R |
| 24 | 330 | T |

| | |
|---------------|----------|
| Bulk Mini | M |
| Bulk Standard | S |



A WIMA part number consists of 18 digits and is composed as follows:

- Field 1 - 4: Type description
- Field 5 - 6: Rated voltage
- Field 7 - 10: Capacitance
- Field 11 - 12: Size and PCM
- Field 13 - 14: Special features (e.g. Snubber versions)
- Field 15: Capacitance tolerance
- Field 16: Packing
- Field 17 - 18: Lead length (untaped)

| | | | | | | | | | | | | | | | | | |
|----------|----------|----------|----------|----------|----------|----------|----------|----------|-------------|----------|----------|----------|----------|----------|----------|----------|----------|
| 1 | 2 | 3 | 4 | 5 | 6 | 7 | 8 | 9 | 10 | 11 | 12 | 13 | 14 | 15 | 16 | 17 | 18 |
| M | K | S | 2 | C | 0 | 2 | 1 | 0 | 0 | 1 | A | 0 | 0 | M | S | S | D |
| MKS 2 | | | | 63 VDC | | 0.01 µF | | | 2.5x6.5x7.2 | | - | | 20% | bulk | 6 -2 | | |

| | | | | |
|---|--|---|--|---|
| <p>Type description:</p> <p>SMD-PET = SMDT SMD-PPS = SMDI FKP 02 = FKP0 MKS 02 = MKS0 FKS 2 = FKS2 FKP 2 = FKP2 MKS 2 = MKS2 MKP 2 = MKP2 FKS 3 = FKS3 FKP 3 = FKP3 MKS 4 = MKS4 MKP 4 = MKP4 MKP 10 = MKP1 FKP 4 = FKP4 FKP 1 = FKP1 MKP-X2 = MKX2 MKP-X2 R = MKXR MKP-Y2 = MKY2 MP 3-X2 = MPX2 MP 3-X1 = MPX1 MP 3-Y2 = MPY2 MP 3R-Y2 = MPRY Snubber MKP = SNMP Snubber FKP = SNFP GTO MKP = GTOM DC-LINK MKP 4 = DCP4 DC-LINK MKP 5 = DCP5 DC-LINK MKP 6 = DCP6 DC-LINK HC = DCH_ SuperCap C = SCSC SuperCap MC = SCMC SuperCap R = SCSR SuperCap MR = SCMR</p> | <p>Rated voltage:</p> <p>2.5 VDC = A1 4 VDC = A2 14 VDC = A3 28 VDC = A4 40 VDC = A5 5 VDC = A6 50 VDC = B0 63 VDC = C0 100 VDC = D0 160 VDC = E0 250 VDC = F0 400 VDC = G0 450 VDC = H0 600 VDC = I0 630 VDC = J0 700 VDC = K0 800 VDC = L0 850 VDC = M0 900 VDC = N0 1000 VDC = O1 1100 VDC = P0 1200 VDC = Q0 1250 VDC = R0 1500 VDC = S0 1600 VDC = T0 2000 VDC = U0 2500 VDC = V0 3000 VDC = W0 4000 VDC = X0 6000 VDC = Y0 250 VAC = 0W 275 VAC = 1W 300 VAC = 2W 400 VAC = 3W 440 VAC = 4W 500 VAC = 5W</p> | <p>Capacitance:</p> <p>22 pF = 0022 47 pF = 0047 100 pF = 0100 150 pF = 0150 220 pF = 0220 330 pF = 0330 470 pF = 0470 680 pF = 0680 1000 pF = 1100 1500 pF = 1150 2200 pF = 1220 3300 pF = 1330 4700 pF = 1470 6800 pF = 1680 0.01 µF = 2100 0.022 µF = 2220 0.047 µF = 2470 0.1 µF = 3100 0.22 µF = 3220 0.47 µF = 3470 1 µF = 4100 2.2 µF = 4220 4.7 µF = 4470 10 µF = 5100 22 µF = 5220 47 µF = 5470 100 µF = 6100 220 µF = 6220 1 F = A010 2.5 F = A025 50 F = A500 100 F = B100 110 F = B110 600 F = B600 1200 F = C120 ...</p> | <p>Size:</p> <p>4.8x3.3x3 Size 1812 = X1 4.8x3.3x4 Size 1812 = X2 5.7x5.1x3.5 Size 2220 = Y1 5.7x5.1x4.5 Size 2220 = Y2 7.2x6.1x3 Size 2824 = T1 7.2x6.1x5 Size 2824 = T2 10.2x7.6x5 Size 4030 = K1 12.7x10.2x6 Size 5040 = V1 15.3x13.7x7 Size 6054 = Q1 2.5x7x4.6 PCM 2.5 = 0B 3x7.5x4.6 PCM 2.5 = 0C 2.5x6.5x7.2 PCM 5 = 1A 3x7.5x7.2 PCM 5 = 1B 2.5x7x10 PCM 7.5 = 2A 3x8.5x10 PCM 7.5 = 2B 3x9x13 PCM 10 = 3A 4x9x13 PCM 10 = 3C 5x11x18 PCM 15 = 4B 6x12.5x18 PCM 15 = 4C 5x14x26.5 PCM 22.5 = 5A 6x15x26.5 PCM 22.5 = 5B 9x19x31.5 PCM 27.5 = 6A 11x21x31.5 PCM 27.5 = 6B 9x19x41.5 PCM 37.5 = 7A 11x22x41.5 PCM 37.5 = 7B 94x49x182 DCH_ = H0 94x77x182 DCH_ = H1 ...</p> <p>Special features:</p> <p>Standard = 00 Version A1 = 1A Version A1.1.1 = 1B Version A1.2 = 1C ...</p> | <p>Tolerance:</p> <p>20% = M 10% = K 5% = J 2.5% = H 1% = E ...</p> <p>Packing:</p> <p>AMMO H16.5 340x340 = A AMMO H16.5 490x370 = B AMMO H18.5 340x340 = C AMMO H18.5 490x370 = D REEL H16.5 360 = F REEL H16.5 500 = H REEL H18.5 360 = I REEL H18.5 500 = J ROLL H16.5 = N ROLL H18.5 = O BLISTER W12 180 = P BLISTER W12 330 = Q BLISTER W16 330 = R BLISTER W24 330 = T Bulk Mini = M Bulk Standard = S Bulk Maxi = G TPS Mini = X TPS Standard = Y ...</p> <p>Lead length (untaped)</p> <p>3.5 ±0.5 = C9 6 -2 = SD 16 ±1 = P1 ...</p> |
|---|--|---|--|---|

The data on this page is not complete and serves only to explain the part number system. Part number information is listed on the pages of the respective WIMA range.