

Double-Layer Capacitor (SuperCap) Modules with Very High Capacitances

Special Features

- Modules with very high capacitance values from 62 F to 500 F and rated voltages from 16 VDC to 125 VDC
- Discharge current up to 1900 A
- Maintenance-free
- Series connected
- Actively balanced
- According to RoHS 2011/65/EU

Construction

Encapsulation: Metal case IP65

Terminal tread size: M8 / M10

Marking: Colour: Black. Marking: Gold

Internal construction:

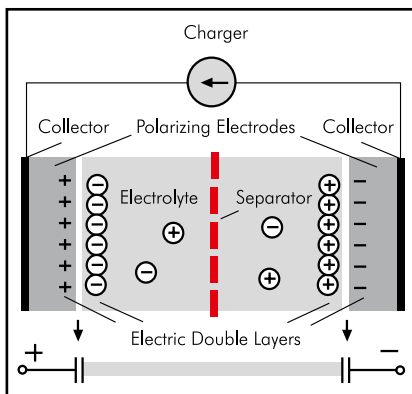

The WIMA PowerBlock range has a modular design. The configurations displayed are representative examples which at any time can be adapted in terms of capacitance, voltage or dimensions. Customized solutions can be realized on request.

Technical Options on Request

- Temperature monitoring
- Overvoltage signal
- Voltage monitoring
- Industrial connector/CAN-connector
- Application-adapted cooling
- Application-specific protection classes

General Data

U _R	C _N	Dimensions			Part number
		W	H	L	
16 V	105 F	157	69	250	MCPBA0B105MC00QV00
	500 F	157	156	250	MCPBA0B500MC00QV00
62.5 V	125 F	283	156	439	MCPBB4B125MC00QV00
125 V	62 F	409	156	575	MCPBDA620MC00QV00



Application:

WIMA PowerBlock modules store energy and release it within short time in e.g.:

- Motor start in construction, agriculture and earth moving machines, trucks, busses, vessels, generators
- Railway technology e.g. locomotives, electric tramway, metro etc.
- Hybrid and heavy transportation in e.g. construction, agricultural and forest machines, city busses, forklifts, cranes etc.
- Automated guided vehicles (AGV) in production facilities, in-plant logistic systems etc.
- Uninterruptible power supply (UPS) in hospitals, telecommunication systems, oil and gas extraction etc.
- Wind power systems e.g. in pitch control.

Advantages:

- Fast supply of several 100 - 1000 A in direct current operation
- Operating temperature range from -40° C to +65° C
- Maintenance-free operation with up to 1 million charge/discharge cycles
- Life expectancy >10 years
- Low weight against batteries or secondary batteries
- Environmentally friendly materials
- No risk of damage do to complete discharge of the component
- Very fast recharge of the PowerBlock.

Conclusion:

The use of PowerBlocks as energy storage increases efficiency and life time of the applications, saves weight and cost for maintenance, and is environmentally friendly.

Continuation

Technical Data

Rated capacitance:	C _N [F]	105	500	125	62
Capacitance tolerance:	[%]	0%/+20%			
Rated voltage:	U _R [V]	16		62.5	125
Max. continuous current¹⁾:	I _C [A, rms]	54	130	130	130
Current, peak (1 sec):	I _P [A]	up to 680	up to 1900	up to 1900	up to 1900
Max. ESR, initial:	R _{bc} [mΩ]	5.2	2.1	8.3	16.4
Max. stored energy: ±20%	E _{max} [Wh]	3.7	17.8	67.8	134.5
Operating temperature:	T _{op} [°C]	-40° C ... +65° C			
Storage temperature:	T _{st} [°C]	-40° C ... +70° C			
Weight:	m [kg]	2.3	4.4	16	31.9
Volume:	V [l]	2.7	6.1	19.4	36.7

Additional Data

Case:	-	AlMg3
Lug terminals:	-	M8 / M10

Comparative Data

Lifetime:					
in hours ²⁾	[h]	90 000, rated voltage, 25° C			
in cycles ³⁾	cycles	>1 million, rated voltage, 25° C			
Energy density:					
gravimetric	E _d [Wh/kg]	1.62	4.03	4.24	4.21
volumetric	E _v [Wh/l]	1.38	2.9	3.5	3.67

M10 x 1.5 negative terminal
tread depth: 20 - 22 mm
max. torque 15 Nm

M8 x 1.25 positive terminal
tread depth: 20 - 22 mm
max. torque 15 Nm

Dims. in mm.

C _N	W ±1	H ±1	L ±1	W1 ±1	L1 ±1	a ±1	b ±1
62 F	409	156	575	376	555	97.1	189
105 F	157	69	250	695	230	47	63
125 F	283	156	439	250	419	46.6	189
500 F	157	156	250	124	230	47	63

1) ΔT = 40° C
 2) Requirements: ΔC < 20% decrease, ESR < 100% increase.
 3) Requirements: ΔC < 20% decrease, ESR < 100% increase.

Rights reserved to amend design data without prior notification.

Fields of Application for WIMA PowerBlock Modules

Motor Start

WIMA PowerBlock Modules replace, protect or support conventional batteries to reliably crank big diesel engines in e.g.:

- Trucks
- Construction, agricultural and earth moving machines
- Busses and trains
- Vessels
- Generators
- etc.

During start-up of a big diesel engine the energy requirement is quite high. By using WIMA PowerBlock modules the battery layout can be designed smaller and thus lower in weight which leads to a significant reduction of fuel cost and emission of harmful substances.

Railway Technology

WIMA PowerBlock modules store braking energy and immediately release it for engine starting, acceleration or peak-load levelling in e.g.:

- Locomotives
- Electric tramway
- etc.

The use of PowerBlock modules as energy storage increases efficiency and life time of transportation systems, saves weight and cost for maintenance, and is environmentally friendly.

Hybrid/Heavy Transportation

WIMA PowerBlock modules in hybrid drives support diesel engines with fast and frequent dynamic loads in e.g.:

- City busses
- Construction machines, agricultural machines and forestry equipment
- Forklifts, cranes
- etc.

The use of WIMA PowerBlock modules as energy storage leads to significant saving in terms of fuel consumption and considerably reduces exhaust and noise emission.

Automated Guided Vehicles (AGV)

WIMA PowerBlock modules serve as rechargeable or exchangeable energy storage in independent, automated guided vehicles (AGV) in e.g.:

- Warehouse and distribution environments
- Production facilities
- In-plant logistic systems
- etc.

The use of PowerBlock modules as energy storage saves weight, reduces cost for maintenance and increases efficiency and life time of the transportation system.

Uninterruptible Power Supply (UPS)

Cascaded WIMA PowerBlock modules are used as emergency power supply in e.g.:

- Hospitals
- Telecommunication systems
- Oil production plants
- Gas extraction
- etc.

By reliably bridging short-term power outages cost-intensive system crashes can be avoided.

WIMA Competence

WIMA has many years of experience in construction of customized energy storage modules based on double layer capacitors. Design and construction of individual solutions is coordinated with the user. Customer's advantages are:

- High expertise due to many years of manufacturing and field experience
- Individual design related to
 - environment
 - space requirements
 - fixing
 - connecting options
- Flexible capacitance or voltage due to serial or parallel cascading of single cells with 350 F to 3,000 F
- Laser-based, reliable welding of the single cells
- Robust, vibration resistant construction according to IP-25 - IP-69 K on demand
- Various technical options, e.g.:
 - temperature monitoring
 - overvoltage signal
 - voltage monitoring
 - industrial connector/CAN-connector
 - application-adapted cooling
 - custom-specific protection class
- Pulse current, endurance and voltage tests accord. to IEC 62576 or DIN EN 62391-1
- Prototype and small series production
- Ready for connection supply.

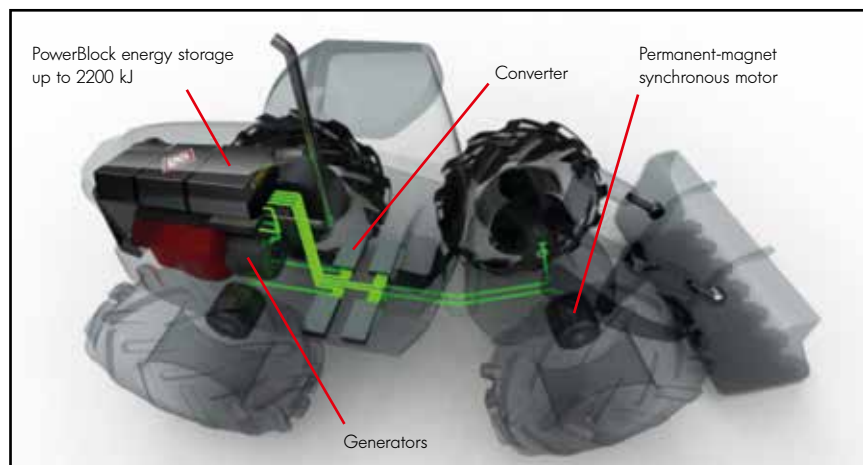

VISEDO electrified wheel-loader using WIMA PowerBlock energy storage modules.